

Füllhöhe = 95% der Tankinnenhöhe !  
 Body stand = 95 % middle high of tank !

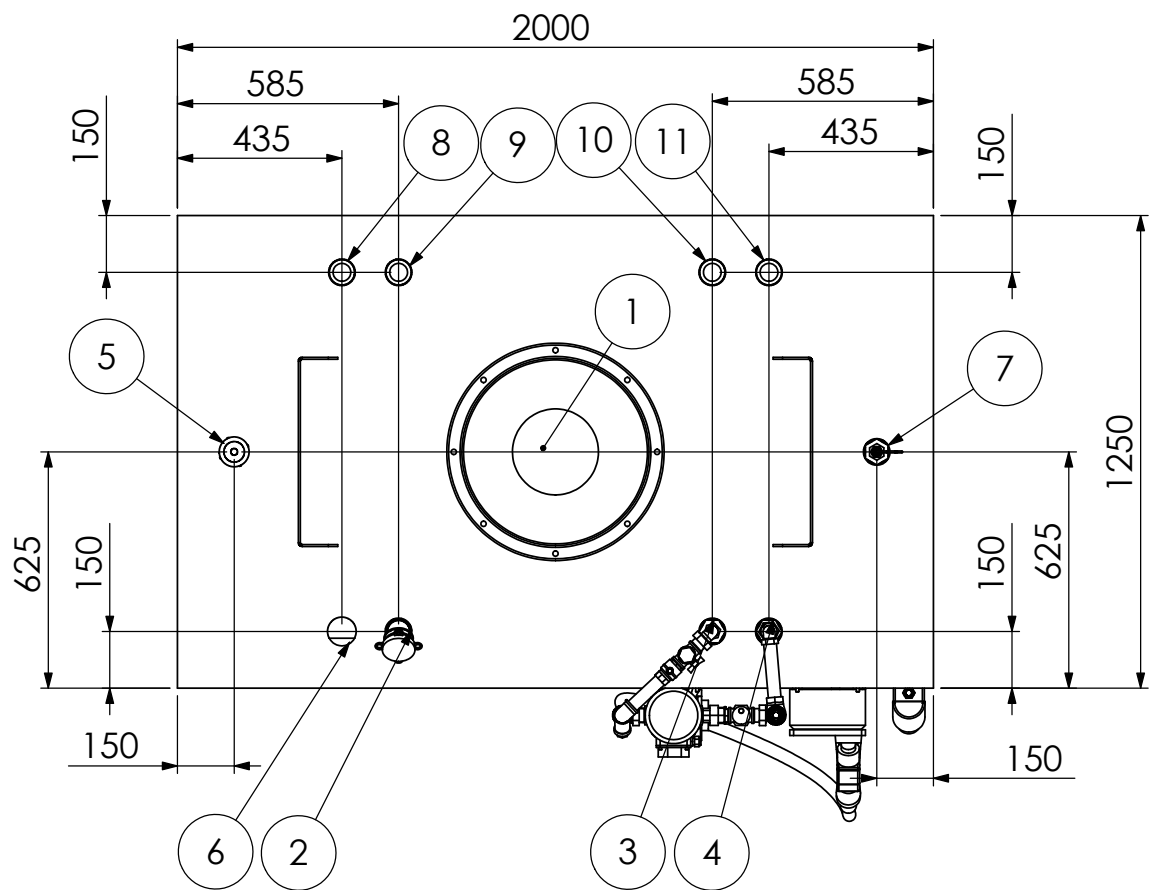
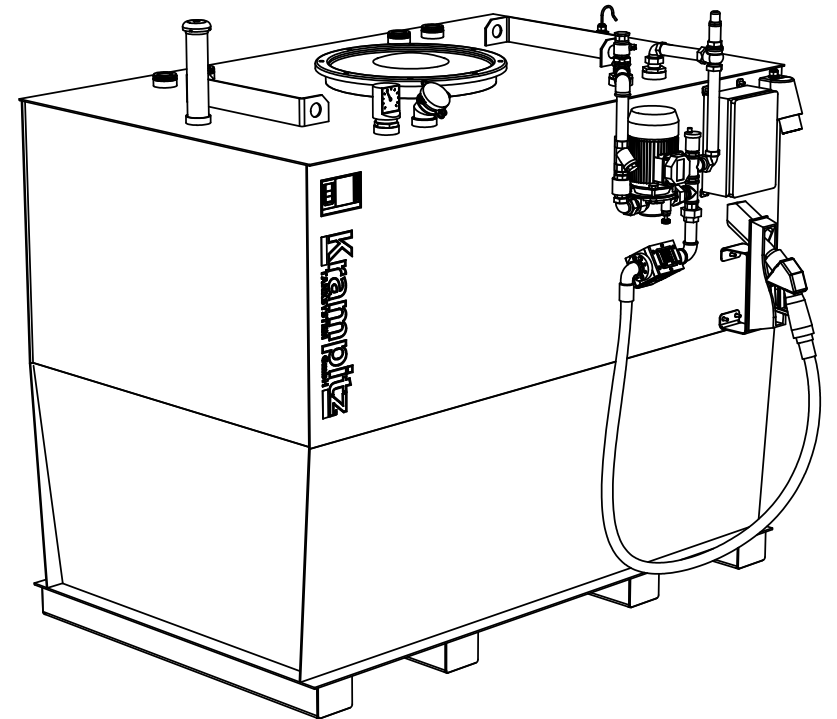
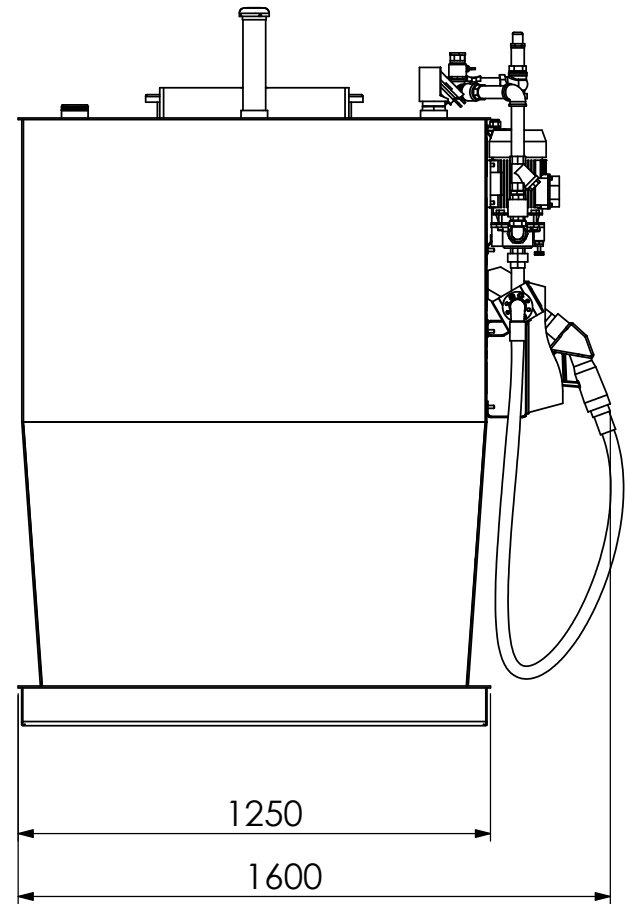
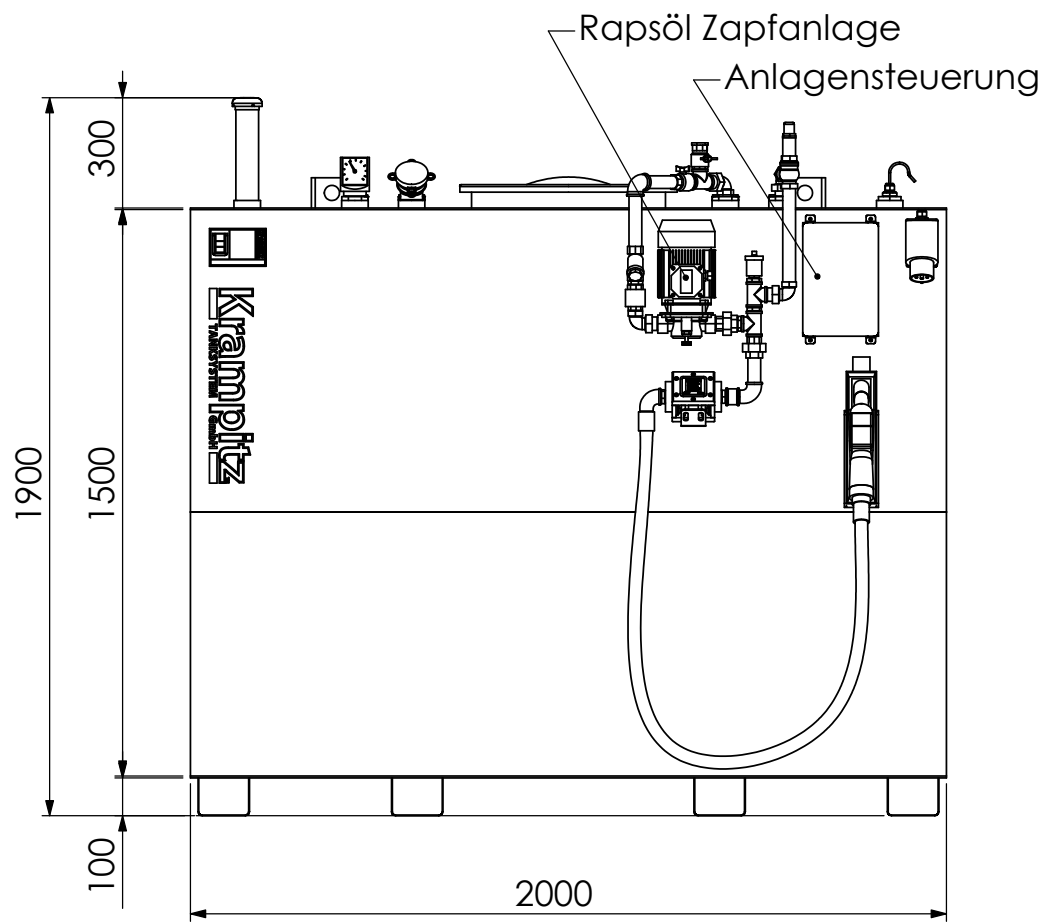

Pos.	Nennweite	Anschluss
1	DN 500	Domeinstieg
2	Muffe G 2"	Tankwagen Befüllstutzen mit Füllrohrverschluss
3	Muffe G 2"	Entnahme - Saugrohr 1" mit Fußventil
4	Muffe G 2"	Anschluß für Rücklauf
5	Muffe G 2"	Entlüftungsstutzen mit Haube
6	Muffe G 2"	Mechanische Inhaltsanzeiger
7	Muffe G 2"	Trockelaufschutz Pumpe
8	Muffe G 2"	Reserve
9	Muffe G 2"	Reserve
10	Muffe G 2"	Reserve
11	Muffe G 2"	Reserve

UNLESS OTHERWISE SPECIFIED: DIMENSIONS ARE IN MILLIMETERS SURFACE FINISH: ----- TOLERANCES:		FINISH:	DEBUR AND BREAK SHARP EDGES	SCALE: 1:20	WEIGHT:
				MATERIAL: S235 JRG2 EN 100 25	
				TITLE: TANKHEXE - Nicht Eichfähig	
				Basis Tanks KTE-3000 Ltr. mit Rapsöl Zapfanlage	
				DWG NO.	A3
				REVISION	SHEET 1 OF 1

Technische Änderungen bleiben vorbehalten!  
 Change reserve !

